

⚠ NOTICE

- Please keep children away during assembly. This item contains small parts that can be dangerous for children. Children should always be under direct adult supervision while using this product.
- Do not discard any of the packaging until you have checked that you have all of the parts and fittings required.
- Carefully remove the contents from the package. If any parts are missing, broken, damaged, do not attempt to use the product until they have been obtained.
- Make sure that each bolt needed for all steps matches the corresponding figure ensure proper assembly.
- Please do not exceed the weight limitations of this item.
- Do not stand on or use any part of this item as a step ladder.
- Firmly secure all bolts, screws and knobs before use.
- Be aware that some parts are heavy and have sharp edges.
- Do not use or store this item in the proximity of open flame or flammable/combustible chemicals.

CLEANING AND MAINTENANCE

- Clean frame with mild soapy water, rinse thoroughly. Dry frame parts completely. Do not use bleach, acid, or other solvents on the fabric and metal parts.
- If outdoor furniture is caught during a sudden rain storm, please make sure to drain any water that may have accumulated inside the frame and dry completely.
- We recommend the use of furniture covers to protect when not in use, and store properly during inclement weather and the winter/rainy seasons.
- Inspect and tighten all bolts on a regular basis to ensure proper performance and safety.
- In order to prolong the life and beauty of your outdoor furniture, we recommend storing it in a dry and protective area during off season periods.

PARTS

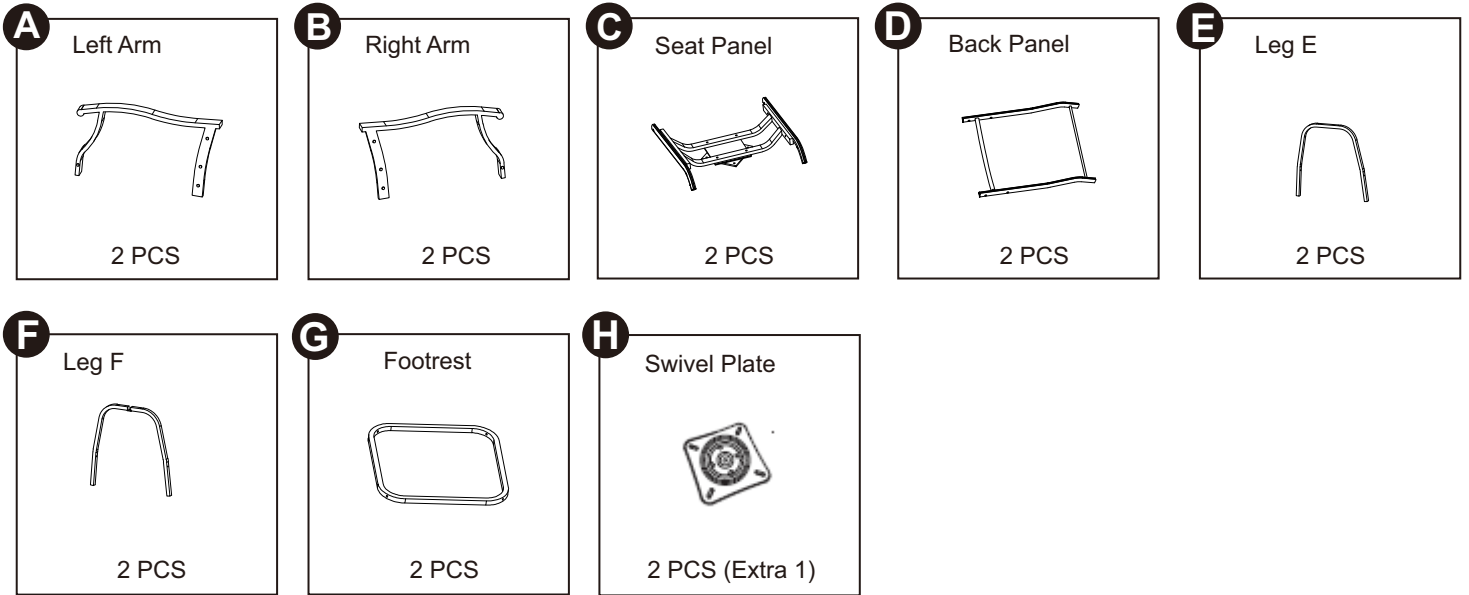

HARDWARE

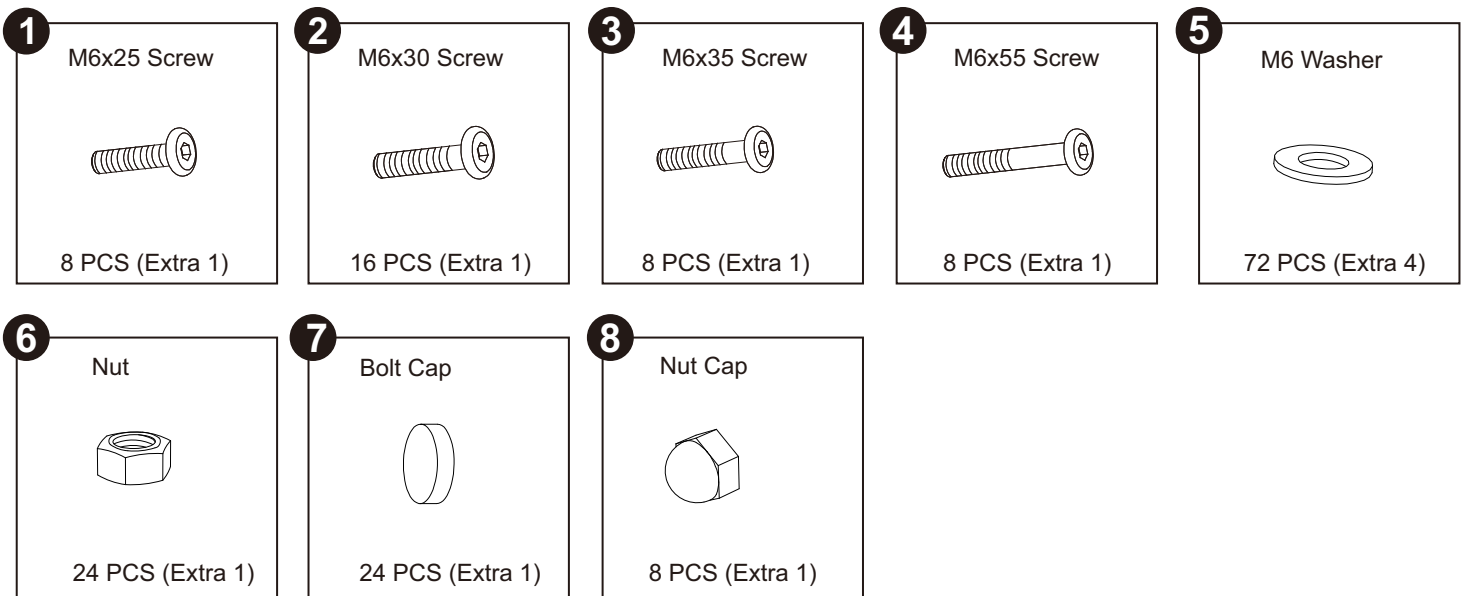

TOOLS REQUIRED



Allen Wrench
1PC

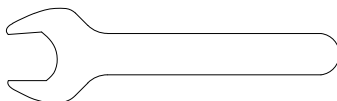

Wrench
1PC



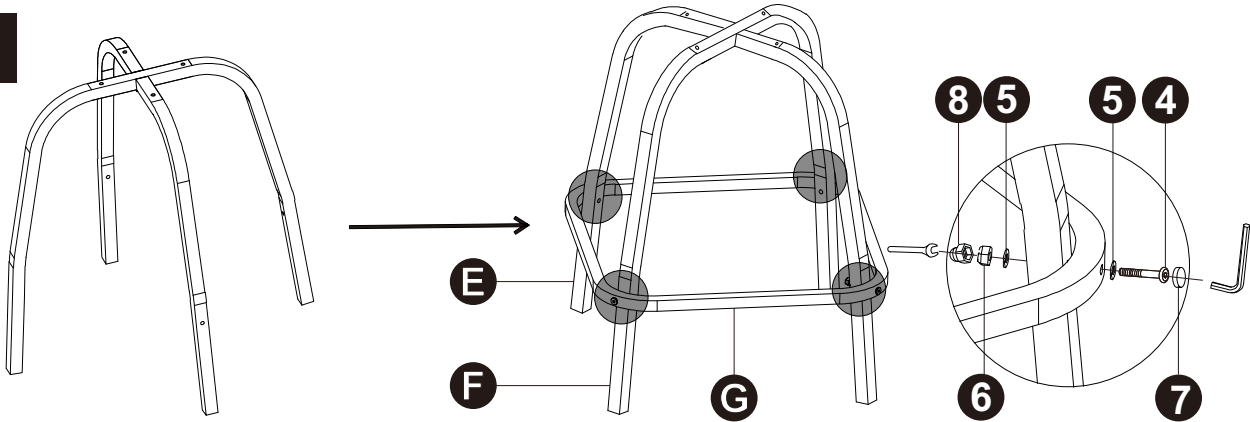

PRODUCT ASSEMBLY

1



Attach footrest (G) to legs (E & F) using screws (4), washers(5), bolt caps (7), nuts (6), nut caps(8), allen wrench and wrench.

NOTE: Please do not fully tighten bolts until unit is fully assembled.

- 4**  4PCS
- 5**  8PCS
- 6**  4PCS
- 7**  4PCS
- 8**  4PCS



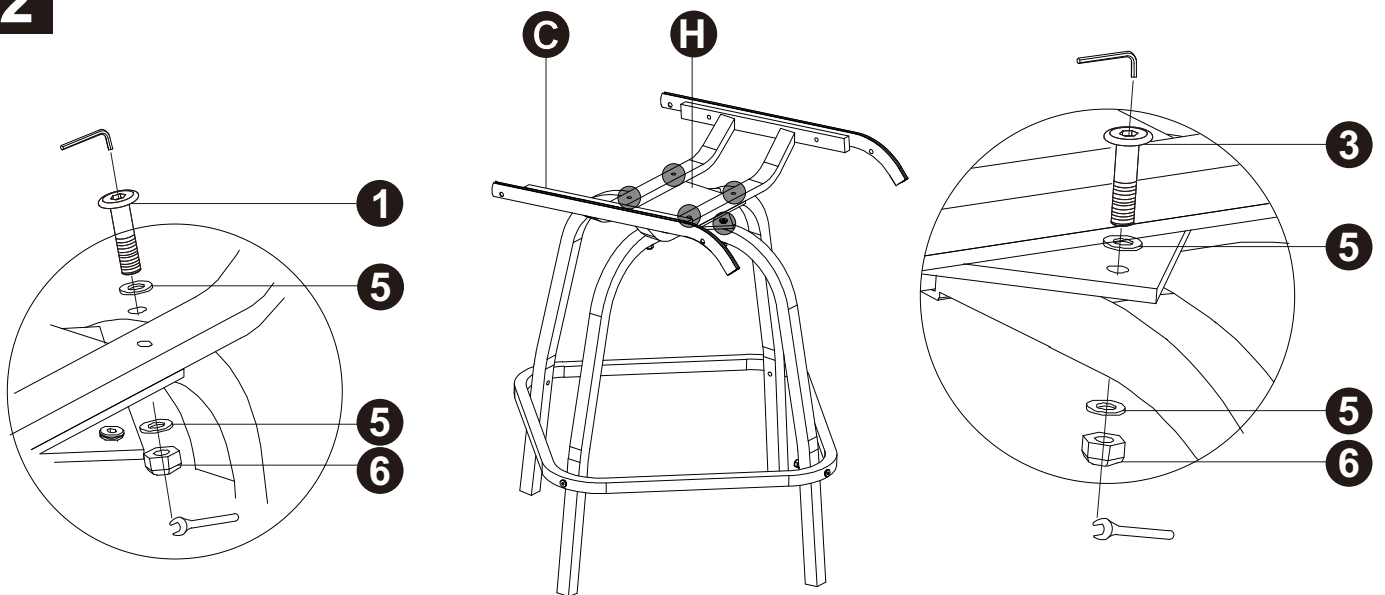

2



Attach swivel plate (H) to seat panel (C) using screws (1), washers (5), nuts (6), allen wrench and wrench.

Attach swivel plate (H) to legs using screws (3), washers (5), nuts (6), allen wrench and wrench.

NOTE: Please do not fully tighten bolts until unit is fully assembled.

- 1**  4PCS
- 3**  4PCS
- 5**  16PCS
- 6**  8PCS

PRODUCT ASSEMBLY

3

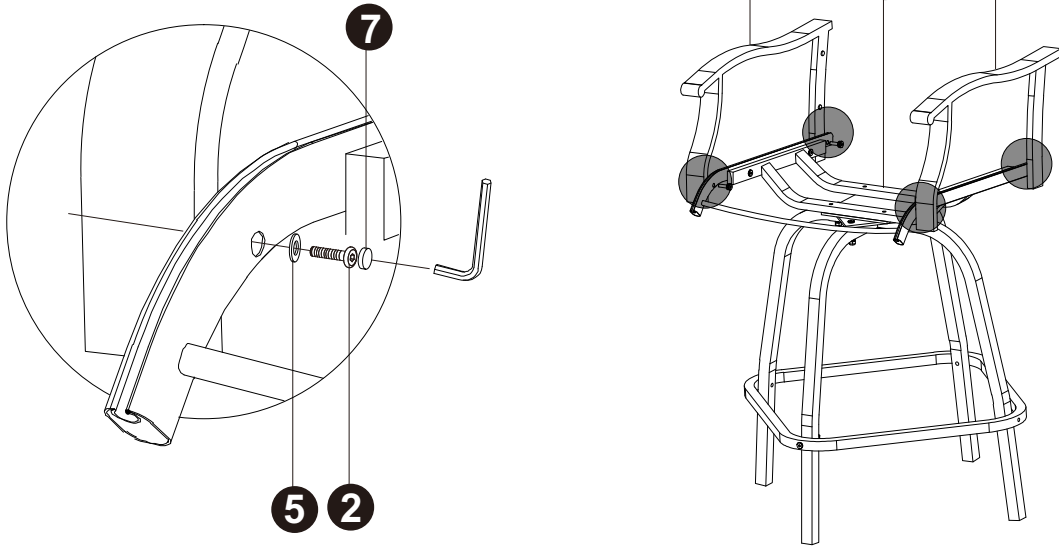

Attach arms (A & B) to seat panel (C) using screws (2), washers (5), bolt caps (7) and allen wrench.

NOTE: Please do not fully tighten bolts until unit is fully assembled.

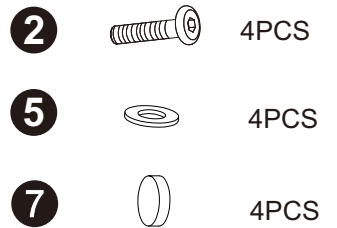

4

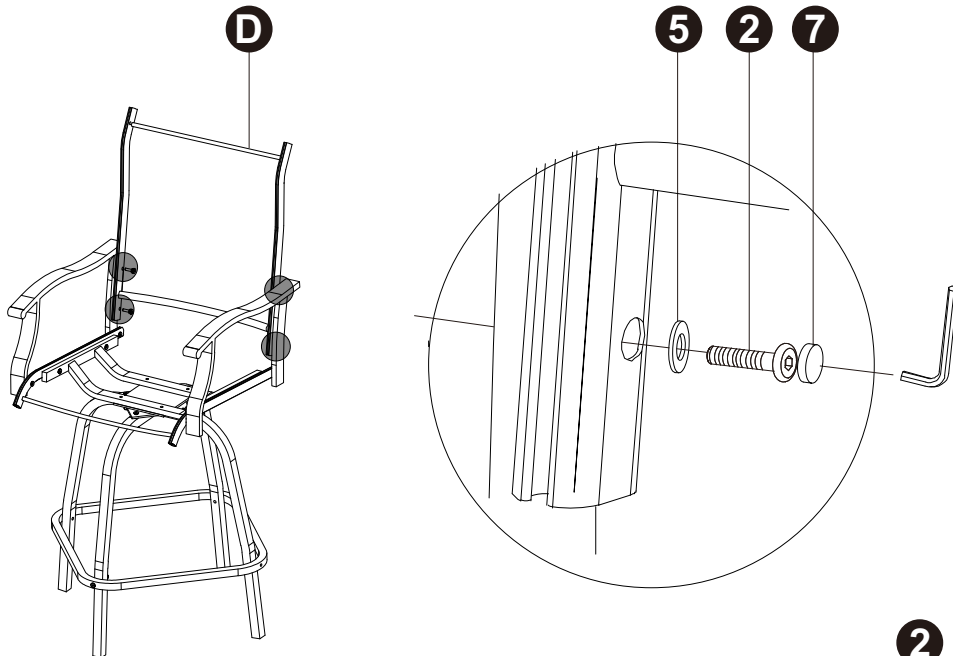

Attach back panel (D) to arms using screws (2), washers (5), bolt nuts (7), and allen wrench.

NOTE: Please fully tighten all bolts at this time.

